



TOBIN ELLIS DRAFT COCKTAIL SYSTEM KEGS
4-Port Kegs



KC5



KC10

JOB	
AREA	
ITEM NO.	
MODEL NO.	

MODELS	
KC5	5 Gallon Keg
KC10	10 Gallon Keg

KEY PRODUCT FEATURES AND BENEFITS

- 4-port keg pairs with the draft cocktail kit for fresh, thoroughly mixed, batched cocktails.
- Circulating pump draws from the bottom of the keg maintaining consistency from the first pour to the last while preventing unwanted agitation
- Quick disconnects minimize labor and make it easy to change out kegs
- NSF Rated



TOBIN ELLIS DRAFT COCKTAIL SYSTEM KEGS
4-Port Kegs

MODEL NUMBERS	KC5	KC10
TOTAL HEIGHT (MM)	25-11/16" (652)	25-1/4" (633)
OUTSIDE DIAMETER (MM)	8-1/2" (216)	12-1/4" (311)
SHIPPING WEIGHT, LBS. (KG)	9.5 (4.3)	23 (10.4)
BEVERAGE CAPACITY (L)	5 Gal (18.93)	10 Gal (37.85)

KC5

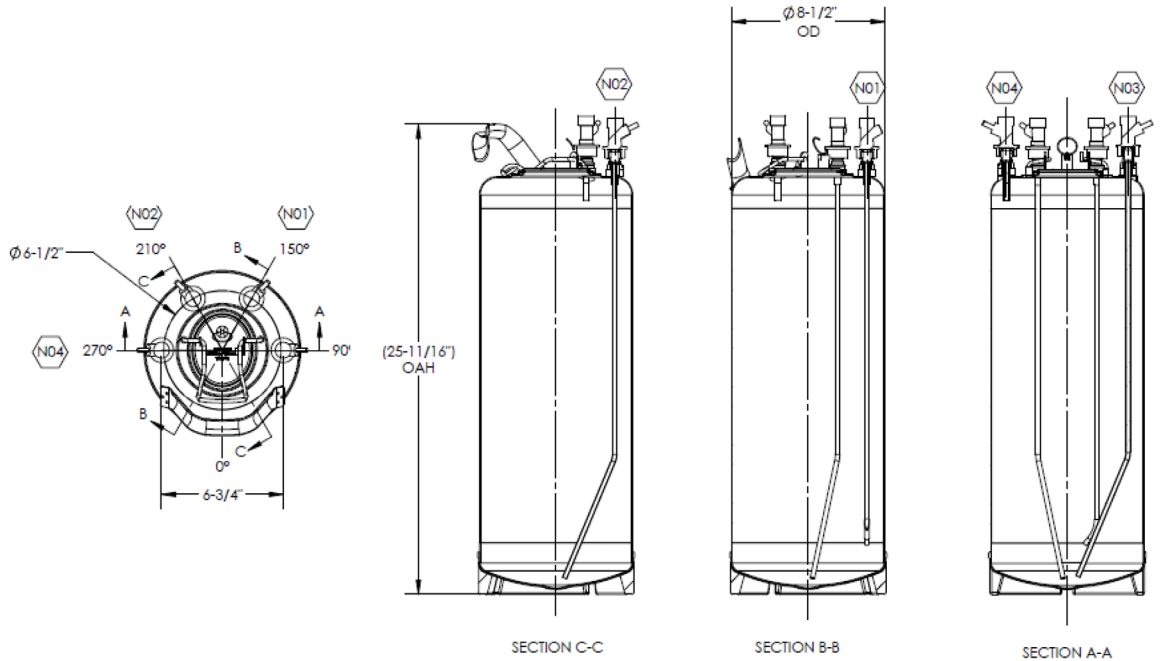

KC10

