

INSTALLATION AND OPERATION INSTRUCTIONS

FLAT TOP BOTTLE COOLER

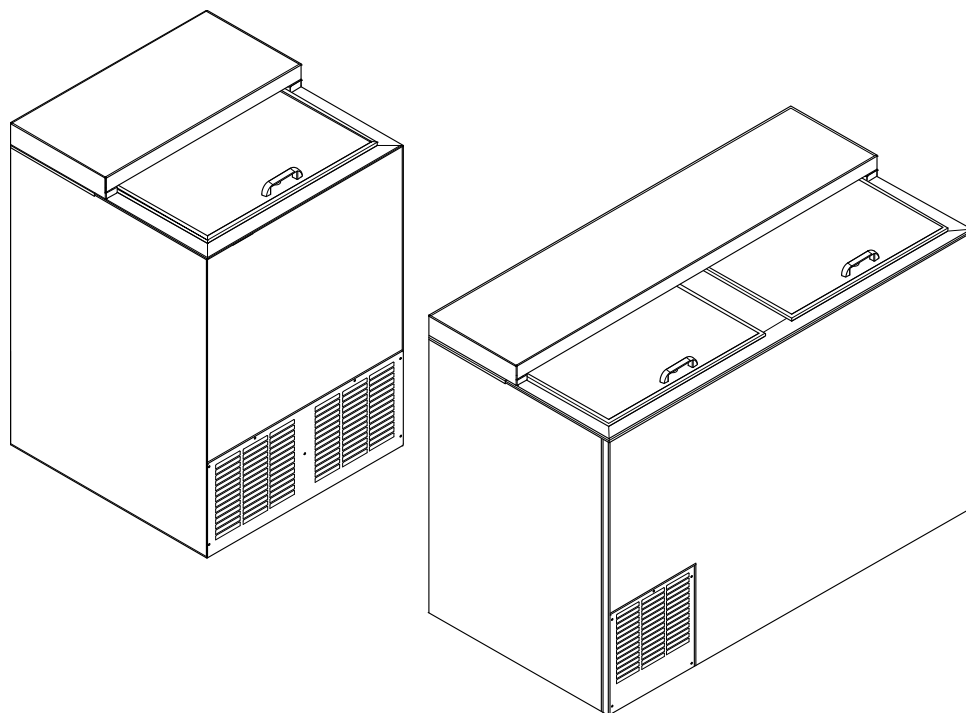

MODEL NOS.

BC24 Series
 BC36 Series
 BC48 Series
 BC48LT Series
 BC60 Series
 BC60LT Series
 BC72 Series
 BC72LT Series
 BC96 Series



* BC36 Model Only



IMPORTANT INFORMATION

This manual has been prepared to assist you in the installation of your Bottle Cooler and to acquaint you with its operation and maintenance.

We dedicate considerable time to ensure that our products provide the highest level of customer satisfaction. If service is required, call Perlick at 1-800-777-7267 or your dealer who can provide you with a list of qualified service agents. For your own protection, never return merchandise for credit without our approval.

We thank you for selecting a Perlick product and assure you of our continuing interest in your satisfaction.

IMPORTANT WARRANTY INFORMATION

To register your product, visit our web site at (www.perlick.com). Click on "Commercial", then "Service". You will see the link to "Warranty Registration Form". You must complete and submit this form or the installation date will revert back to the ship Date.

Table of Contents

Cabinet Specifications	2
Installing	
Uncrating and Inspection.....	3
Plumbing	3
Electrical.....	3
Adjusting Partitions	3
Installing Casters and Legs.....	3
Placing the Cabinet.....	3
Sealing to the Floor	3
Temperature Control.....	4
Cleaning the Cabinet.....	4
Wiring Diagrams.....	5/6
Replacement Parts.....	7/8



8300 West Good Hope Road • Milwaukee, WI 53223 • Phone 414-353-7060 • Fax 414-353-7069
 Toll Free 800-558-5592 • E-Mail: Perlick@Perlick.com • www.Perlick.com

Installation and Operating Instructions

Sizes and Specifications, Flat Top Bottle Coolers

MODELS	BC24	BC36  **	BC48/BC48LT	BC60/BC60LT	BC72/BC72LT	BC96
LENGTH (mm)	24" (610)	36" (915)	48" (1219)	60" (1524)	72" (1828)	96" (2438)
INTERIOR CU. FT. (m ³)	3.75 (0.10)	7.83 (0.22)	11.68 (0.33)	15.53 (0.44)	19.38 (0.55)	27.08 (0.77)
CASE CAPACITY (12oz. bottles)	5.5	9.75	17.2	21	28.3	41
CASE CAPACITY (12oz. cans)	7	16	25	30	36	58
CONDENSING UNIT H.P.	1/5	1/5	1/4	1/3	1/3	1/3
AMPS	3.2	3.0	5.2	7.0	6.9	7.6
SHIP WT lbs. (kg)	190 (86)	245 (111)	300 (136)	353 (160)	405 (184)	515 (235)
INTERIOR	All models have stainless steel walls and floor.					
EXTERIOR	Choice of black, stainless steel and all stainless. Black Option: Front and ends are black vinyl coated steel, back and bottom are galvanized. Stainless Steel Option: Front and ends are stainless steel, back and bottom are galvanized. All Stainless Option: Front, ends, back and bottom are all stainless steel.					
TEMPERATURE (Approximate factory settings)	38°F/Standard Model. 30°F Low-Temp Model					
DOORS (Sliding)	Stainless steel top and bottom pans. Die cast handle. Optional locks.					
ELECTRICAL	115V, 60 Hz., 1 Phase. Furnished with 6 foot rubber plug-in cord (115V model only). Also available in 230V, 50Hz., 1 Phase AC. Carries CE marking of conformity.					
PLUMBING	No drain required. Condensate evaporates automatically.					
INSULATION	2 inch foamed-in-place polyurethane insulation.					
REFRIGERATION	R134a capillary tube/type with hermetic condensing unit. Pulls out for service and cleaning.					
VENTILATION	2' model is front vented, all other models require 2" clearance from wall on either left end or back of cabinet for proper air flow.					
OPTIONAL ACCESSORIES	<ul style="list-style-type: none"> • Floor racks • Casters • Bottle opener and receiver • Interior light • Bin dividers • Speed rails • Wine temperature (specify red or white) • Interior light kit • Adjustable legs • Roller basket shelving • Door locks 					

* This equipment is intended for the storage and display of non-potentially hazardous bottled or canned products only.

** BC36 Model Only

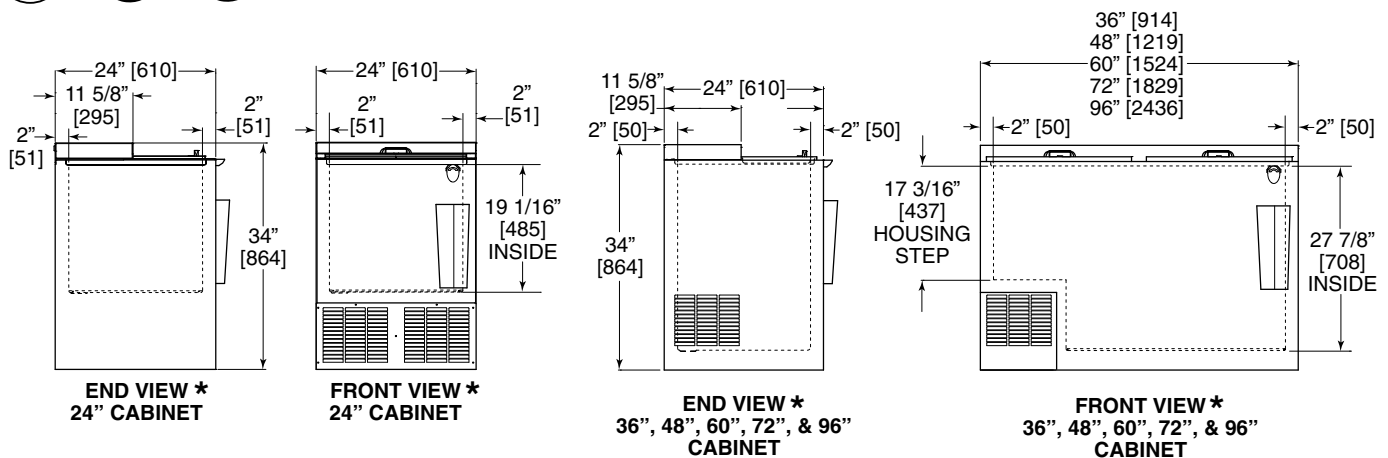

* Shown with optional opener and receiver.



Perlick is committed to continuous improvement. Therefore, we reserve the right to change specifications without prior notice.

Preparing the Cabinet – Flat Top Bottle Coolers

Uncrating and Inspection

Remove all crating material before operating. Carefully inspect cabinet for hidden damage. If damage is discovered, file your claim immediately with the transport company. Perlick is not responsible for damage in transit.

Plumbing

No plumbing connections are required. Condensate from the cooling coil automatically evaporated through a condensate pan located in the condensing unit section.

Electrical

The cabinet must be connected to a separately fused power source (see Electrical Specification Plate) and grounded in accordance with National and Local Electrical Codes.

Caution: Do not attempt to operate the equipment on any other power source than that listed on the Electrical Specification Plate.

Adjustable Partitions & Shelving

Perlick Bottle Coolers may be provided with adjustable partitions and shelving which will accommodate various bottle sizes.

- Remove bottles and cans from their cases before placing in cooler to ensure proper air flow.
- On 2' and 3' models keep air intake open for proper circulation.

Installing Casters or Legs (optional)

Attach casters or legs to the cabinet bottom in holes provided. Use the supplied 1/4"-20 hex head self-tapping machine screws. If unit is tipped on its back for an extended period of time, wait 24 hours after unit is uprighted to plug the unit in.

Placing the Cabinet

To assure maximum performance, fresh air must be allowed to circulate through the machinery compartment. It is important to allow at least two inches of clearance at the back or left end of the cabinet. Do not place anything in front of the cabinet that would obstruct air flow at these grilles. Do not place the unit in an unventilated small room.

CAUTION:

Removing the factory installed back clearance spacers without providing proper left side grill clearance for compressor air flow will void the warranty.

Cabinet should be leveled.

For sanitation purposes, it may be necessary to seal the base of the cabinet to the floor. This can be accomplished by laying a bead of silicone sealant along the base of the cabinet as shown by the figure below.

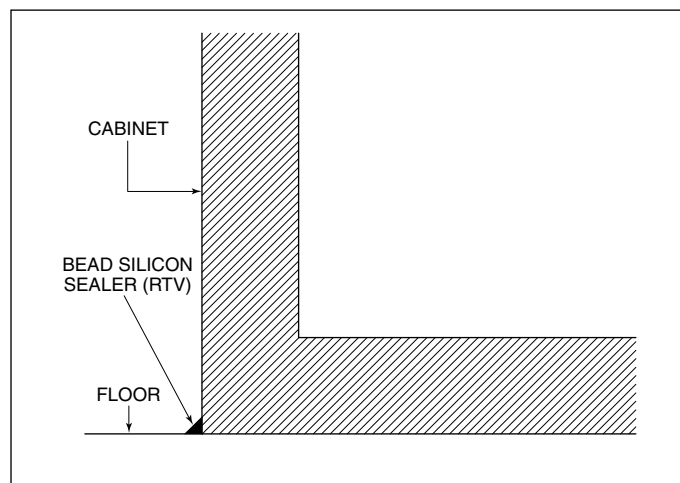

How To Operate – Flat Top Bottle Coolers

Temperature Control

An adjustable temperature control is located inside the Bottle Cooler on the evaporator fan panel assembly. It is factory set at approximately 38° F for standard refrigeration and approximately 30° F for low temperature models. Make adjustments as detailed below to attain the desired temperature.

NOTE: A temperature setting that is too low will not allow enough condensing unit “off” time to maintain a frost-free coil.

- **Colder Temperatures:** Turn the adjusting screw clockwise (to the right).
- **Warmer Temperatures:** Turn the adjusting screw counterclockwise (to the left).
- **Temperature Control “OFF”:** Turn the adjusting screw completely counterclockwise to the “O” position until a “click” is noted.

The condenser fan motor turns off and on with the compressor. The evaporator fan motor runs continuously.

Cleaning the Condenser:

- The condenser (located behind the front grille) should be inspected every 30 days, and cleaned, if necessary. Failure to keep the condenser clean will cause a loss in condensing unit efficiency, or compressor failure.

Avoiding Stainless Steel Corrosion:

Corrosion can be prevented by following product cautions, cleaning instructions and avoiding use of certain chemicals or objects which will cause stainless steel corrosion.

STAINLESS STEEL ENEMY

- Steel wool or steel scouring pads
- Cherry/Orange/Olive juice
- Chlorine Bleach
- Sharp Objects

Cleanig the Doors:

- Doors should be periodically removed from the cabinet and inspected for a buildup of foreign materials, such as syrups, beer, etc. Buildups on the underside of the doors, along with the cabinet breaker strips on which they ride, will cause them to bind, and therefore, not function as designed. If dirty, these surfaces should be cleaned with a mild detergent and water and then coated with a silicone lubricating material. Aerosol silicone sprays can be obtained locally at most hardware or automotive stores.

To remove doors:

- With door closed, lift it upward by its handle and slide forward until door clears the cabinet top. Use the reverse procedure to reinstall the doors.

Cleaning the Cabinet:

- Use a damp cloth with a mild detergent and water to clean the inside and outside of the cabinet. Dry thoroughly. Do not allow cleaning agents or large amounts of water to go down the drain. Use an acceptable stainless steel polish to clean all stainless steel surfaces. Never use steel wool or scouring pads to clean stainless steel.



Wiring Diagram – Flat Top Bottle Coolers

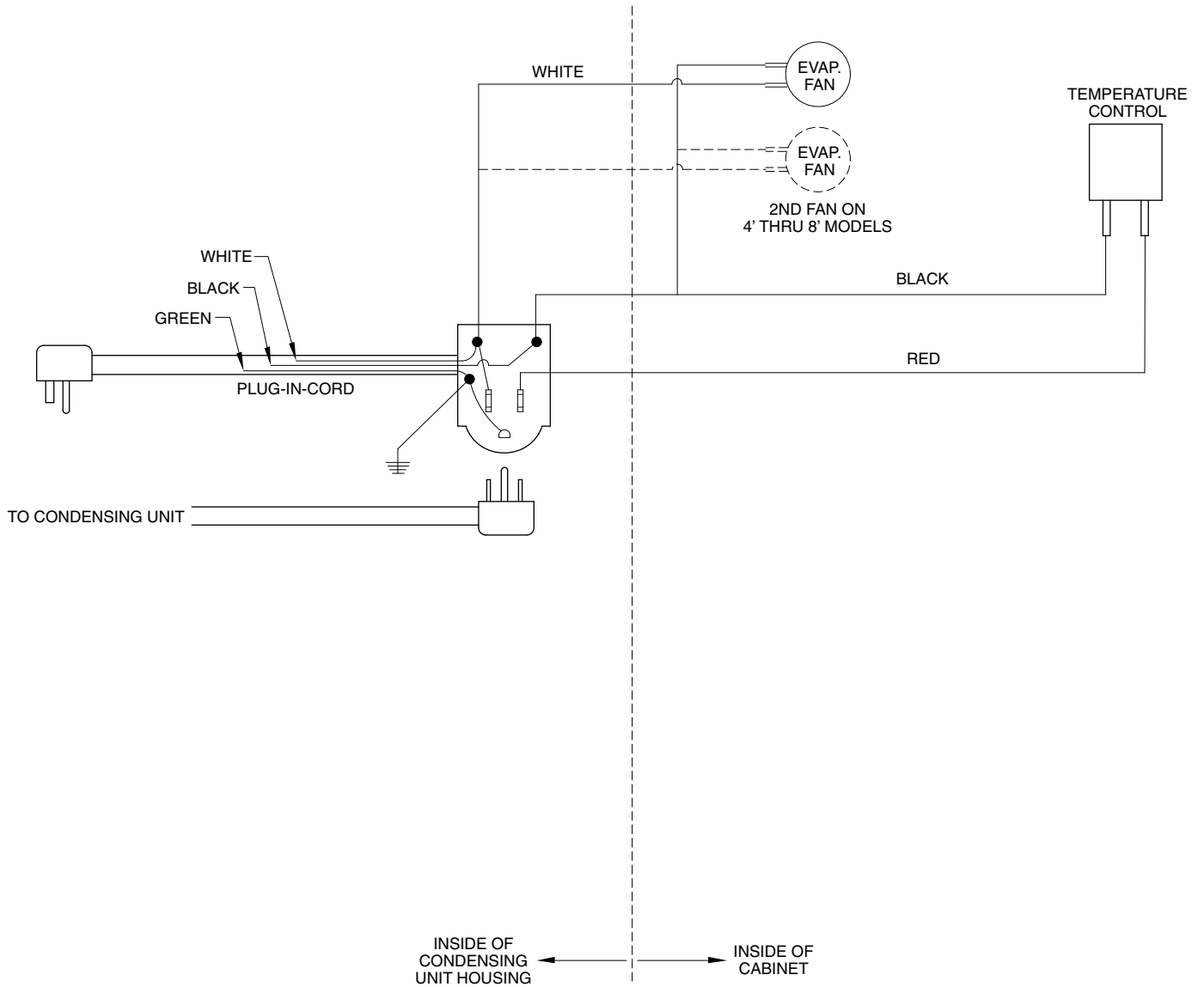

Wiring Diagram – Low-Temp Bottle Coolers

WIRING DIAGRAM FOR LOW TEMPERATURE BOTTLE COOLER – BC48LT, BC60LT & BC72LT

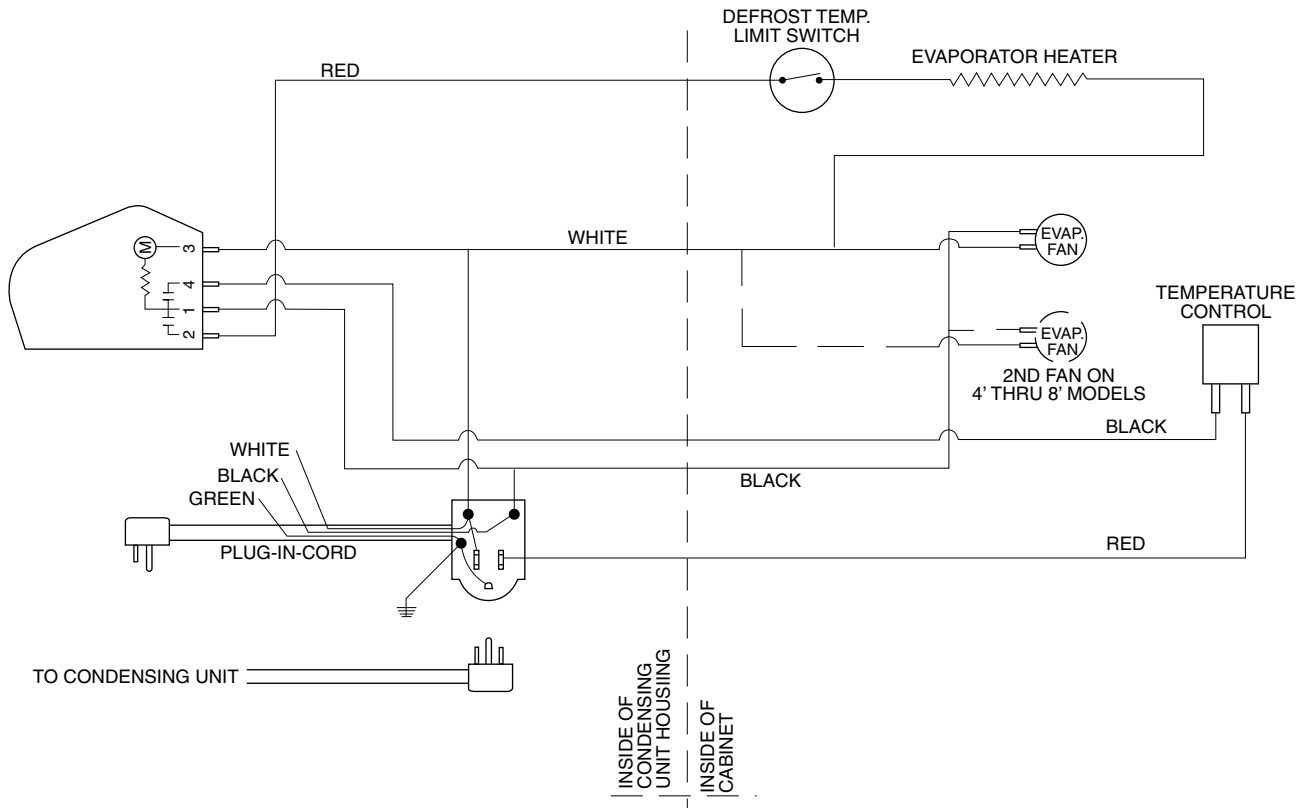

Perlick is committed to continuous improvement. Therefore, we reserve the right to change specifications without prior notice.

Replacement Parts – Flat Top Bottle Coolers

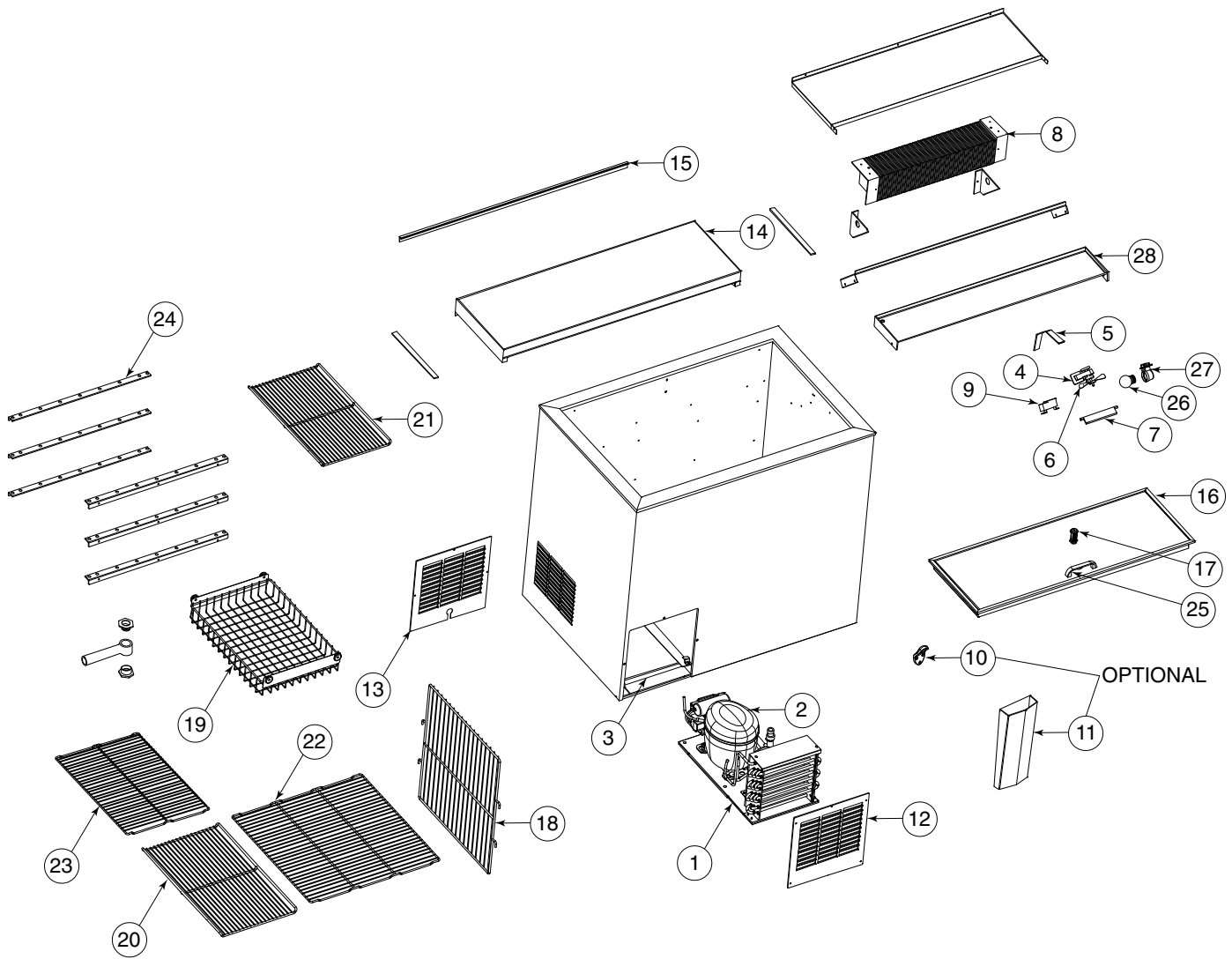

CAUTION

- Service should be done by a qualified refrigeration technician.
- Disconnect all power before servicing the cabinet.

Replacement Parts – Flat Top Bottle Coolers

MODEL NOS.		BC24	BC36	BC48/BC48LT	BC60/BC60LT	BC72/BC72LT	BC96
Item	Description	Part Numbers					
1	Complete condensing unit	C22648	C22648	C22647	C22646	C22646	C22646
2	Replacement compressor, R134a	513307046	513307046	513200314UA.2	513200003	513200003	513200003
	Condensing unit fan motor assy.	515315009	515315009	515315009	515315009	515315009	515315009
	Terminal Board	519100088	519100088	519100088	519100088	519100088	519100088
	Overload Protector	513634530	513634530	US-PB10HBX1	US-PB12HBX1	US-PB12HBX1	US-PB12HBX1
	Relay	513514069	513514069	US-PB10HBX1	US-PB12HBX1	US-PB12HBX1	US-PB12HBX1
	Start capacitor	N/A	N/A	US-PB10HBX1	US-PB12HBX1	US-PB12HBX1	US-PB12HBX1
3	Condensate pan	64537	64626-1	64626-1	64626-1	64626-1	64626-1
4	Evaporator fan motor(s)	C15239A	C15239A	C15239A	C15239A	C15239A	C15239A
5	Evaporator fan motor bracket	65671-1	65671-1	60988-1	60988-1	60988-1	60988-1
6	Evaporator fan motor blade	63461	63461	57699	57699	57699	57699
7	Evaporator fan guard	65666	65666	65557	65557	65557	65557
8	Evaporator coil	64785-1EP	C17511-1EP	C17511-1EP	C17511-2EP	C17511-2EP	C17511-2EP
9	Temperature control	61283	61283	61283	61283	61283	61283
10	Bottle opener	C6713-1	C6713-1	C6713-1	C6713-1	C6713-1	C6713-1
11	Bottle cap receiver	C17332SS	C17332SS	C17332SS	C17332SS	C17332SS	C17332SS
12	Front grille	66498-3A	65662-1A	65662-1A	65662-1A	65662-1A	65662-1A
13	Rear grille/panel	66498-1	65662-3	65662-3	65662-3	65662-3	65662-3
14	Top assembly	RT-SL2	RT-SL2	RT-SL2	RT-SL2	RT-SL2	RT-SL2
15	Top wiper gasket	63671-24	63671-36	63671-48	63671-60	63671-72	63671-96
16	Door assembly	RD-SL2	RD-SL2	RD-SL2	RD-SL2	RD-SL2	RD-SL2
17	Lock assembly	63940	63940	63940	63940	63940	63940
18	Vertical partition	66503	66441	66441	66441	66441	66441
19	Roller basket	N/A	66442-1	66442-1	66442-1	66442-1	66442-1
20	Wide shelf	N/A	64811-1	64811-1	64811-1	64811-1	64811-1
21	Narrow shelf	64809-1	64809-1	64809-1	64809-1	64809-1	64809-1
22	Bottom floor rack (wide)	64814-1	64814-1	64814-1	64814-1	64814-1	64814-1
23	Bottom floor rack (narrow)	N/A	N/A	64815-1	64815-1	64815-1	N/A
24	Shelf bracket	65653-24	65653-36	65653-48	65653-60	65653-72	65653-96
25	Door handle	63931	63931	63931	63931	63931	63931
26	Light bulb	C15046	C15046	C15046	C15046	C15046	C15046
27	Light socket	63484	63484	63484	63484	63484	63484
28	Evaporator drain pan	65670-24	65670-36	65526-1SL	65526-2SL	65526-2SL	65526-2SL
	ITEMS NOT SHOWN						
	Wire harness, main	65043-1	65043-1	65044-1	65044-1	65044-1	65044-1
	Suction line/cap tube heat exchanger with drier	65072	65072	65073	65075	65074	65220
	Mullion assembly	N/A	N/A	66551	66551	66551	66551
	Refrigerant charge (oz. R134a)	6.0	8.5	9.0	9.0	9.0	9.0



8300 West Good Hope Road • Milwaukee, WI 53223 • Phone 414-353-7060 • Fax 414-353-7069
Toll Free 800-558-5592 • E-Mail: Perlick@Perlick.com • www.Perlick.com