

ICE CREAM CENTER

MODELS

TS Series

□ TS24DC

MODELS

TSD Series

□ TSD24DC



Perlick Features

- Underbar module for refrigerated ice cream unit (8000 Ice Cream Freezer must be ordered separately)
- Convenient disher well and faucet
- Stainless steel legs install without tools and have "Rust Free" Thermoplastic feet.

Form No. DC01
Rev. 09.20.2011



8300 West Good Hope Road • Milwaukee, WI 53223 • Phone 414.353.7060 • Fax 414.353.7069
Toll Free 800.558.5592 • E-Mail perlick@perlick.com • www.perlick.com

Size and Specifications

Ice Cream Center

Job _____
 Area _____
 Item No. _____
 Model No. _____

MODEL NOS.	TS(D)24DC
LENGTH IN. (mm)	24" (610)
SHIP WT. LBS. (kg)	199 (90)
TOP, FRONT & SIDES	Stainless steel
BACK & BOTTOM	Galvanized steel
BACKSPLASH	TS Series: Stainless steel 6" high (4" high optional) with 1" return at top, mechanically fastened and sealed with steel support brackets. TSD Series: Stainless steel rear deck.
LEGS	1-5/8" tubular, stainless steel with 1" adjustable plastic thermoplastic foot.
DISH WELL & FAUCET	5" stainless steel disher well with removable perforated basket. Chrome-plated fine-stream faucet.
DROP-IN ICE CREAM UNIT	Stainless steel top and removable hinged door lid. Ice cream well: No. 2B dull stainless steel. NSF listed. Must be ordered separately.
ELECTRICAL	115 volt, 60 hz, 1 phase AC. Furnished with six foot rubber cord. Running load: 4 amps. Also available in 230 volt, 50 hz, 1 phase CE marked
REFRIGERATION	1/5 h.p.
PLUMBING	Drain-connection- 1" NPS Male. Cold Water connection: 1/2" IPS shank (includes 1/4" MPT tailpiece).

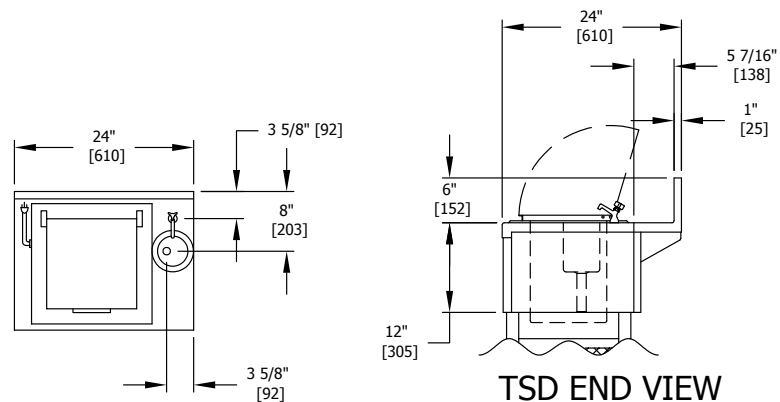

**Drop-in Ice Cream Unit shown for clarity; must be ordered separately*

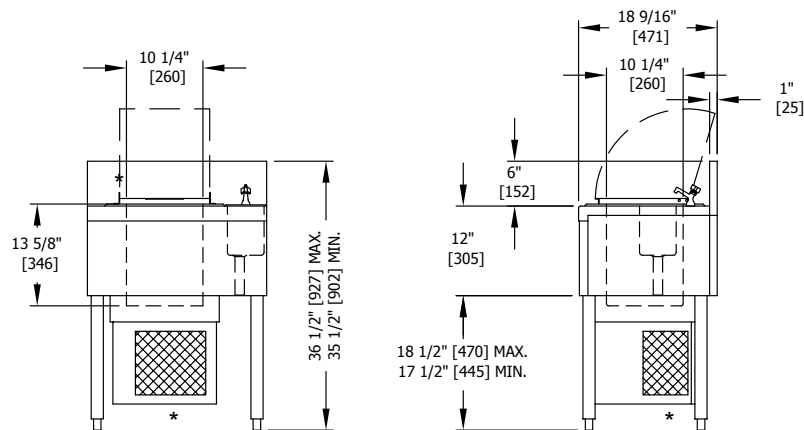

Form No. DC01
 Rev. 09.20.2011



8300 West Good Hope Road • Milwaukee, WI 53223 • Phone 414.353.7060 • Fax 414.353.7069
 Toll Free 800.558.5592 • E-Mail perlick@perlick.com • www.perlick.com

Perlick is committed to continuous improvement. Therefore, we reserve the right to change specifications without prior notice