

DRIP PANS

Perlick Features

- Variety of sizes, and configurations to fit any installation.
- Available in stainless steel or tarnish-free brass.
- Removable, glass rack.

MODEL NOS.

- Top-Mounted
- Angled
- Recessed
- Spacesaver
- Cutout



No. 5020



No. 57120

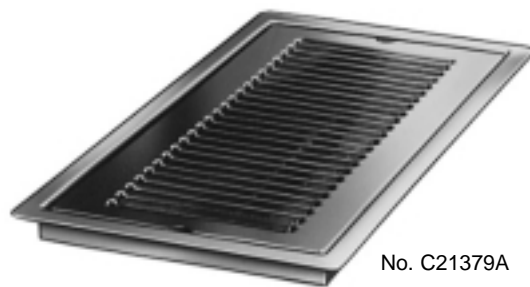

No. C21379A



Sizes and Specifications Drip Pans - Top Mounted

Job _____
 Area _____
 Item No. _____
 Model No. _____

TOP MOUNTED

5000 SERIES MODEL NOS.	Stainless Steel	5015	5020	5025	5028	5030
	Tarnish-Free Brass	5015TF	5020TF	5025TF	5028TF	5030TF
OVERALL LENGTH (mm)		5 ⁷ / ₈ " (137)	13 ³ / ₄ " (349)	19" (483)	24" (610)	37" (940)
DRIP PAN LENGTH (mm)		4 ⁷ / ₈ " (111)	12 ³ / ₄ " (324)	18" (457)	23" (584)	36 ¹ / ₈ " (918)
OVERALL WIDTH (mm)		5 ⁷ / ₈ " (137)	4 ⁷ / ₈ " (124)	4 ⁷ / ₈ " (124)	4 ⁷ / ₈ " (124)	4 ⁷ / ₈ " (124)
DRIP PAN WIDTH (mm)		4 ³ / ₈ " (111)	3 ⁷ / ₈ " (98)	3 ⁷ / ₈ " (98)	3 ⁷ / ₈ " (98)	3 ⁷ / ₈ " (98)
DRIP PAN and GLASS RACK	No. 4 finish, type 302 stainless steel or tarnish-free brass.					
PLUMBING	Equipped with ⁹ / ₁₆ " I.D. waste drain and universal drain tubes. Use with ¹ / ₂ " N.P.T. pipe fittings or 1390D ¹ / ₂ " I.D. flexible drain tube.					

1800 SERIES MODEL NOS.	Stainless Steel	C18635A	C18640A	C18645A	C18650A	C18655	C18660
	Tarnish-Free Brass	C18635ATF	C18640ATF	C18645ATF	C18650ATF	C18655TF	C18660TF
OVERALL LENGTH (mm)		8 ³ / ₄ " (222)	14 ³ / ₁₆ " (360)	20 ³ / ₄ " (527)	26 ³ / ₄ " (679)	33" (838)	49 ⁹ / ₁₆ " (1259)
DRIP PAN LENGTH (mm)		7 ⁷ / ₁₆ " (179)	12 ⁷ / ₈ " (327)	19 ⁷ / ₁₆ " (494)	25 ⁷ / ₁₆ " (646)	31 ¹ / ₂ " (800)	45 ⁵ / ₁₆ " (1151)
OVERALL WIDTH (mm)		7 ³ / ₄ " (197)	7 ³ / ₄ " (197)	7 ³ / ₄ " (197)	7 ³ / ₄ " (197)	7 ³ / ₄ " (197)	7 ³ / ₄ " (197)
DRIP PAN WIDTH (mm)		6 ¹ / ₂ " (165)	6 ¹ / ₂ " (165)	6 ¹ / ₂ " (165)	6 ¹ / ₂ " (165)	6 ¹ / ₂ " (165)	6 ¹ / ₂ " (165)
DRIP PAN and GLASS RACK	No. 4 finish, type 302 stainless steel or tarnish-free brass.						
PLUMBING	Equipped with ⁹ / ₁₆ " I.D. waste drain and universal drain tubes. Use with ¹ / ₂ " N.P.T. pipe fittings or 1390D ¹ / ₂ " I.D. flexible drain tube.						

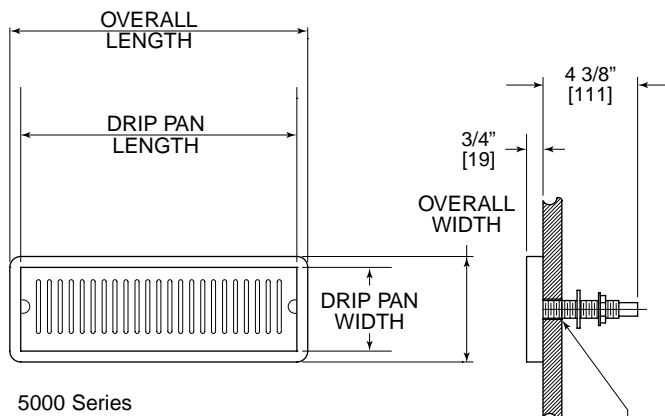

TO INSTALL DRIP PAN,
 DRILL 15/16" [24] DIA. HOLE
 THRU COUNTER TOP.

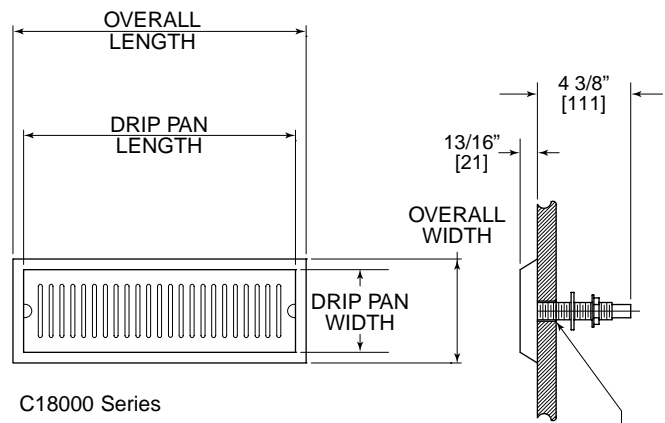

TO INSTALL DRIP PAN,
 DRILL 15/16" [24] DIA. HOLE
 THRU COUNTER TOP.

ANGLED SERIES MODEL NOS.	Stainless Steel	57120
	Tarnish-Free Brass	57120TF
OVERALL LENGTH (mm)		20 ⁷ / ₈ " (511)
OVERALL WIDTH (mm)		9" (227)
DRIP PAN and GLASS RACK	No. 4 finish, type 302 stainless steel or tarnish-free brass. White plastic glass rack.	
PLUMBING	Equipped with ⁹ / ₁₆ " I.D. waste drain and universal drain tubes. Use with ¹ / ₂ " N.P.T. pipe fittings or 1390D ¹ / ₂ " I.D. flexible drain tube.	

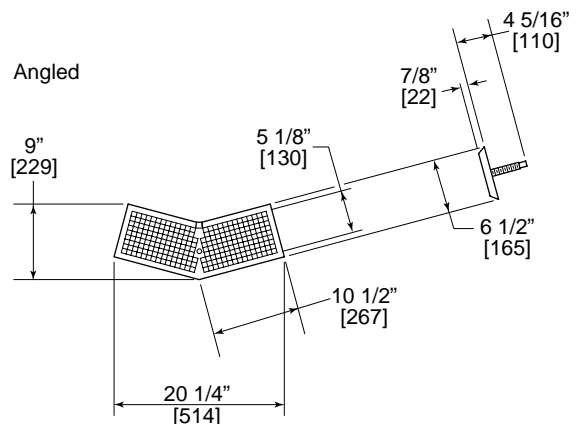

Sizes and Specifications — Drip Pans

Recessed, Cutout and Spacesaver

Job _____
 Area _____
 Item No. _____
 Model No. _____

RECESSED

MODEL NOS.	Stainless Steel	C11988A	C21379A	C32357	C32257	58979
	Tarnish-Free Brass	C11988ATF	C21379ATF	C32357TF	C32257TF	58979TF
OVERALL LENGTH (mm)		8 ⁵ / ₈ " (219)	14 ¹ / ₁₆ " (357)	19 ¹ / ₄ " (489)	20 ⁵ / ₈ " (524)	37 ⁵ / ₁₆ " (948)
DRIP PAN LENGTH (mm)		7 ¹ / ₁₆ " (179)	12 ⁷ / ₈ " (327)	18 ³ / ₁₆ " (462)	19 ⁷ / ₁₆ " (494)	36 ¹ / ₈ " (918)
OVERALL WIDTH (mm)		7 ⁵ / ₈ " (194)	7 ⁵ / ₈ " (194)	5 ¹ / ₁₆ " (129)	7 ⁵ / ₈ " (194)	5 ¹ / ₈ " (130)
DRIP PAN WIDTH (mm)		6 ⁷ / ₁₆ " (164)	6 ⁷ / ₁₆ " (164)	4" (102)	6 ⁷ / ₁₆ " (164)	3 ³ / ₈ " (98)
DRIP PAN and GLASS RACK	No. 4 finish, type 302 stainless steel or tarnish-free brass.					
PLUMBING	Equipped with ⁹ / ₁₆ " I.D. waste drain and universal drain tubes. Use with ¹ / ₂ " N.P.T. pipe fittings or 1390D ¹ / ₂ " I.D. flexible drain tube.					

CUTOUT

MODEL NOS.	Stainless Steel	62303SS		
	Tarnish-Free Brass	62302	62303	62304
DIMENSIONS "A" (mm)		16" (406)	19 ¹ / ₁₆ " (500)	19 ¹ / ₁₆ " (500)
DIMENSIONS "B" (mm)		8 ⁷ / ₈ " (225)	9 ⁷ / ₈ " (251)	9 ⁷ / ₈ " (251)
DIMENSIONS "C" (mm)		5 ⁷ / ₈ " (149)	8 ⁹ / ₁₆ " (217)	10 ¹ / ₄ " (260)
DRIP PAN and GLASS RACK	Brass or stainless steel. Stainless steel glass rack.			
PLUMBING	Chrome plated brass drain and ³ / ₈ " elbow hose coupling.			

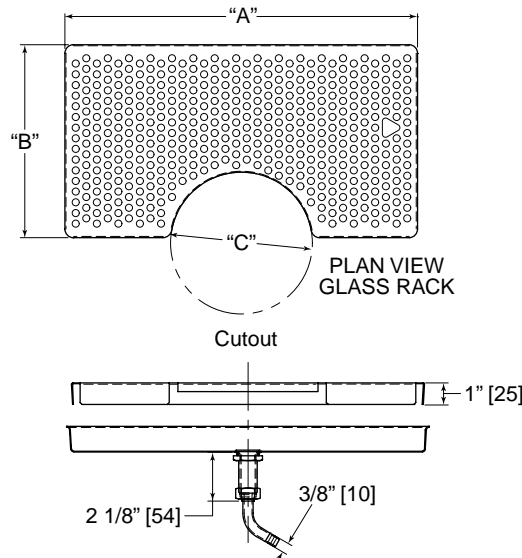
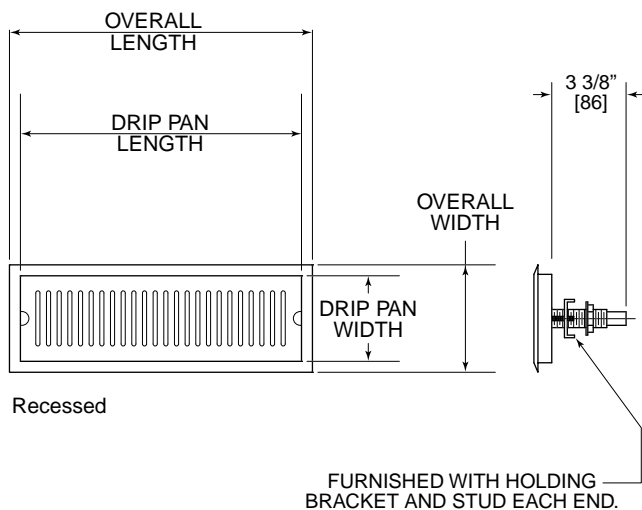

SPACESAVER DRIP PANS

MODEL NOS.	Stainless Steel	3713-1	3721-1
LENGTH (mm)		12 ⁷ / ₈ " (327)	21 ¹ / ₈ " (537)
DEPTH (mm)		8 ⁷ / ₈ " (225)	8 ⁷ / ₈ " (225)
HEIGHT (mm)		14 ³ / ₄ " (375)	14 ³ / ₄ " (375)
DRIP PAN and GLASS RACK	No. 4 finish, type 302 stainless steel.		
PLUMBING	Equipped with ⁹ / ₁₆ " I.D. waste drain and universal drain tubes. Use with ¹ / ₂ " N.P.T. pipe fittings or 1390D ¹ / ₂ " I.D. flexible drain tube.		

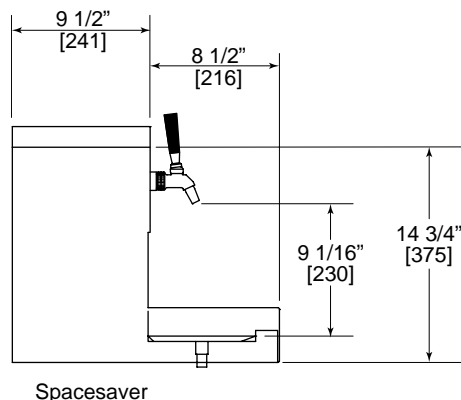

Sizes and Specifications Compatible Heads and Drip Pans

	TOP MOUNTED											RECESSED				CUTOUT			SPACE SACER				
	5015	5020	5025	5028	5030	C18635A	C18640A	C18645A	C18650A	C18655	C18660	57120	C11988A	C21379A	C32357	C32257	58979	62302	62303	62304	3713-1	3721-1	
DRAFT ARMS																							
1 FAUCET (4010)	■					■							■										
2 FAUCET (4016)		■					■							■									
3 FAUCET (4026)		■					■							■									
TEE TOWERS																							
2 FAUCET (4006-2B)		■					■							■									
3 FAUCET (4006-3B)		■					■							■									
4 FAUCET (4006-4B)		■					■							■									
5 FAUCET (4006-5B)			■					■							■	■							
6 FAUCET (4006-6B)			■					■							■	■							
7 FAUCET (4006-7B)				■					■						■	■							
8 FAUCET (4006S8B)				■					■														
BRIDGE TOWERS																							
8 FAUCET (4006-8B)					■					■							■						
9 FAUCET (4006-9B)					■					■							■						
10 FAUCET (4006-10B)					■					■							■						
11 FAUCET (4006-11B)					■					■							■						
12 FAUCET (4006-12B)					■					■							■						
GAMBRINUS																							
3 FAUCET (4005-3B)		■					■				■			■						■			
4 FAUCET (4005-4B)		■					■				■			■						■			
5 FAUCET (4005-5B)								■			■				■					■			
6 FAUCET (4005-6B)																				■			
13" SPACESAVER																							
2 FAUCET (4040A2B)																							■
3 FAUCET (4040A3B)																							■
4 FAUCET (4040A4B)																							■
21" SPACESAVER																							
2 FAUCET (4060A2B)																							■
3 FAUCET (4060A3B)																							■
4 FAUCET (4060A4B)																							■
5 FAUCET (4060A5B)																							■
6 FAUCET (4060A6B)																							■
7 FAUCET (4060A7B)																							■
PIPE TOWERS																							
6 FAUCET (4008-6B)				■					■														
8 FAUCET (4008-8B)				■					■														
10 FAUCET (4009-10B)					■					■													
12 FAUCET (4009-12B)					■						■												
NAPOLI																							
2 FAUCET (4053)		■					■							■									
FIRENZA																							
1 FAUCET (4051WH1B)	■					■							■					■					
2 FAUCET (4051WH2B)		■					■							■				■					
ROMA																							
3 FAUCET (4056-3B)											■									■			
4 FAUCET (4056-4B)											■									■			
5 FAUCET (4056-5B)											■									■			
TORINO - COLLAR STYLE																							
1 FAUCET (4054-1B)											■											■	
2 FAUCET (4054-2B)											■											■	
3 FAUCET (4054-3B)											■											■	
TORINO - BEAM STYLE																							
3 FAUCET (4055-3B)		■					■							■								■	
4 FAUCET (4055-4B)		■					■							■								■	
5 FAUCET (4055-5B)			■					■							■	■						■	
6 FAUCET (4055-6B)			■					■							■	■						■	
7 FAUCET (4055-7B)				■					■						■	■						■	



8300 West Good Hope Road • Milwaukee, WI 53223 • Phone 414-353-7060 • Fax 414-353-7069
 Toll Free 800-558-5592 • E-Mail: Perlick@Perlick.com • www.Perlick.com